

ÉTANCHE 48 - SCHÉMAS DE CONNEXION

**INTERRUPTEUR UNIPOLAIRE**

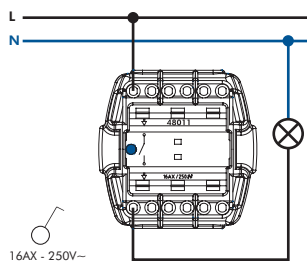

**INTERRUPTEUR LUMINEUX**

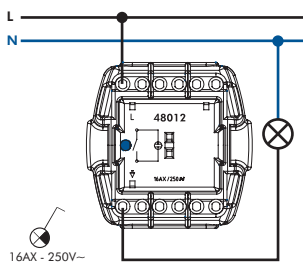

**INTERRUPTEUR TÉMOIN**

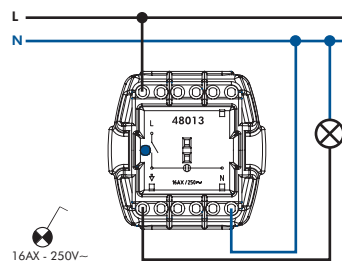

**INTERRUPTEUR BIPOLAIRE**

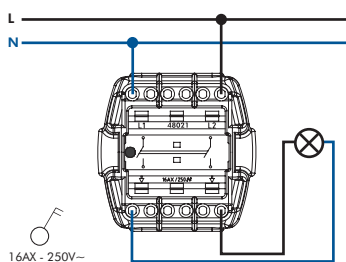

**INTERRUPTEUR BIPOLAIRE TÉMOIN**

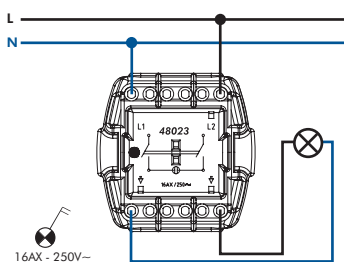

**DOUBLE ALLUMAGE**

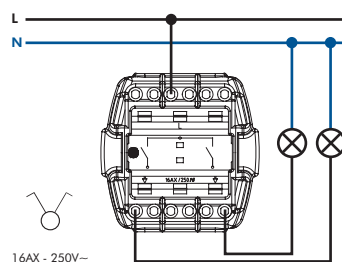

**VA-ET-VIENT**

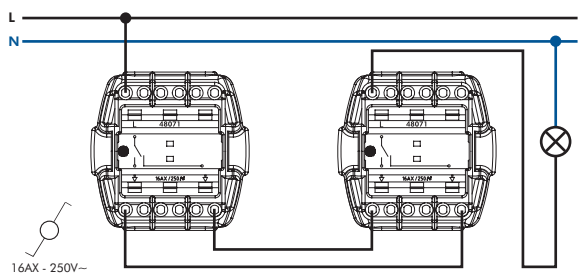

**VA-ET-VIENT LUMINEUX**

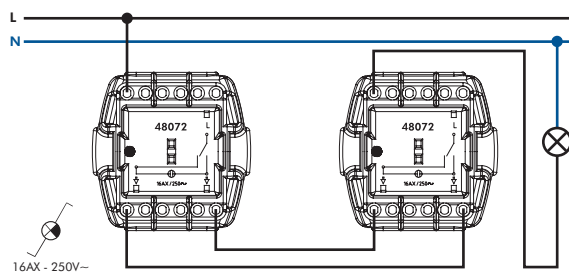

**VA-ET-VIENT TÉMOIN**

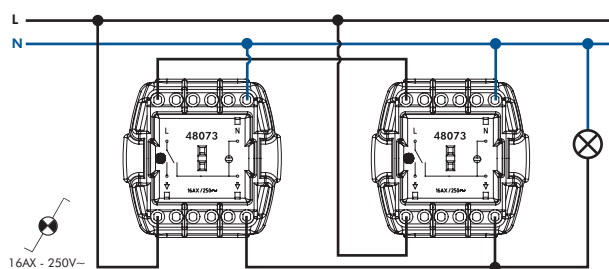

**VA-ET-VIENT DOUBLE - 10A ET 20A**

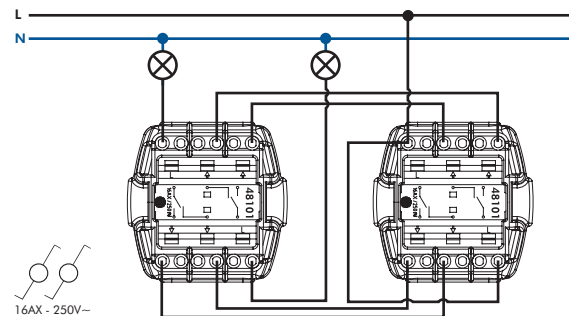

**PERMUTATEUR**

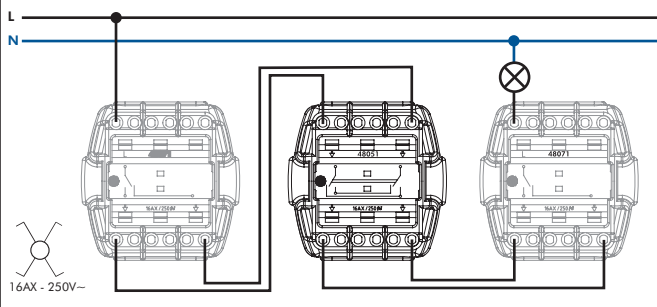

**PERMUTATEUR LUMINEUX**

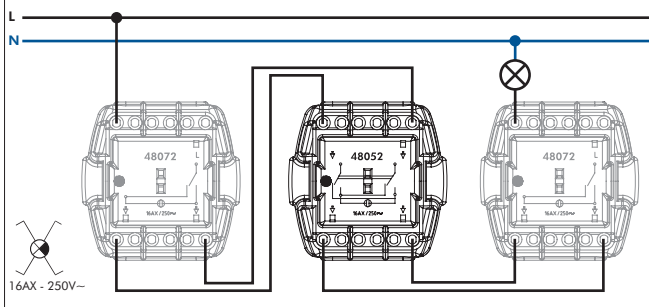

ÉTANCHE 48 - SCHÉMAS DE CONNEXION

